

TX120A

DIGITAL LINE TEST SET (DLTS)

A multi-function tester for the qualification of copper pairs prior to the installation of high speed digital equipment such as pair gain systems, xDSL and ISDN

OPERATING INSTRUCTIONS

teletech

CONTENTS

1	INTRODUCTION	3
2	FUNCTIONS	4
3	GENERAL DESCRIPTION	5
3.1	SENDER	5
3.2	RECEIVER	6
3.3	PROBE	6
4	OPERATING MODES	7
4.1	EXCHANGE CONNECT	7
4.2	PAIR IDENTIFICATION	8
4.3	820Hz INSERTION LOSS	8
4.4	3kHz INSERTION LOSS	9
4.5	HIGH FREQUENCY INSERTION LOSS	9
4.6	NOISE	10
4.7	LINE BALANCE	10
4.8	LINE LOOP / LOOP RESISTANCE	11
4.9	OPEN	11
4.10	INSULATION RESISTANCE	12
4.11	CALIBRATION CHECK	12
5	USING THE SENDER	13
5.1	SENDER FEATURES	13
5.2	POWER ON	14
5.3	TEST LEADS	14
5.4	POWER LEAD	15
5.5	BATTERY TEST	15
5.6	SELECTING THE OPERATING MODE	15
5.7	DISPLAY	17
5.7.1	BATTERY STATUS INDICATION	17
5.7.2	WARBLE RATE INDICATION	17
5.7.3	ADDRESS INDICATION	18

CONTENTS

6	USING THE RECEIVER	19
6.1	RECEIVER FEATURES	19
6.2	POWER ON	21
6.2.1	RECEIVER BATTERY CHECK	21
6.2.2	SENDER BATTERY CHECK	21
6.3	POWER OFF	22
6.4	ADDRESS	23
6.5	TEST LEADS	23
6.6	OPERATING MODE	24
6.6.1	EXCHANGE CONNECT MODE	25
6.6.2	PAIR IDENTIFY MODE	25
6.6.3	820Hz (600 Ω) INSERTION LOSS MODE	26
6.6.4	820Hz (TN12) INSERTION LOSS MODE	26
6.6.5	3kHz (600 Ω) INSERTION LOSS MODE	27
6.6.6	3kHz (TN12) INSERTION LOSS MODE	27
6.6.7	HF INSERTION LOSS MODE	27
6.6.8	NOISE MODE	28
6.6.9	LINE BALANCE MODE	28
6.6.10	LINE LOOP MODE	29
6.6.11	OPEN MODE	30
6.6.12	500V INSULATION RESISTANCE MODE	31
6.6.13	CALIBRATION CHECK MODE	33
7	USING THE PROBE	36
7.1	PROBE FEATURES	36
7.2	OPERATION	36
8	APPLICATIONS	37
8.1	USING DIFFERENT WARBLE RATES	37
8.2	USING DIFFERENT ADDRESSES	37
9	TROUBLESHOOTING	39
10	TECHNICAL SPECIFICATIONS	41
11	ORDER CODES	43

1 INTRODUCTION

Loading Coils and Build Out Capacitors are necessary components on many POTS (Plain Old Telephone System) lines. Bridged Taps (Laterals or Multiples), Split Pairs and other causes of Unbalance, Poor Joints and Low Insulation Resistance, are conditions that, while not strictly allowed on a POTS line, are often tolerated.

All of these conditions, however, seriously affect the operation of high frequency digital systems such as Pair Gain Systems, ISDN and ADSL.

They must, therefore, be identified and eliminated.

The TX120A is a hand held, battery powered, multi-function instrument that enables an unassisted operator to carry out a comprehensive series of tests which will determine the ability of the pair under consideration to support a high frequency system.

IMPORTANT NOTE : Because of the possibility of sparks being created by the breaking of electrical connections, this instrument must not be used in areas in which flammable gases exist, or may exist.

2 FUNCTIONS

The TX120A will perform the following functions :

- Remote control of the connection of the pair under test (PUT) to the exchange.
- Pair Identification using a distinctive warble tone.
- Insertion Loss measurement at 820Hz with either 600 Ω or TN12 complex termination.
- Insertion Loss measurement at 3kHz with either 600 Ω or TN12 complex termination.
- Insertion Loss measurement at 40kHz, 100kHz, 300kHz with 120 Ω termination.
- Noise measurement.
- Longitudinal Balance measurement for detection of split pairs and other forms of line unbalance.
- Remote end line looping for Pulse Echo Tester (PET) distance calibration and Bridge Fault Location.
- Loop Resistance measurement.
- Remote end line isolation.
- DC Voltage measurement.
- Insulation Resistance measurement at 500VDC.
- Self-calibration check of SENDER against RECEIVER.

3 GENERAL DESCRIPTION

The TX120A consists of three units, the SENDER, the RECEIVER and the PROBE.

Each is powered by a 9V alkaline battery and utilises circuitry designed to maximise battery life. In addition, the SENDER can be powered from the 48V exchange battery.

Both SENDER and RECEIVER have a two line by sixteen character, alphanumeric LCD display for operator instructions and measurement results.

3.1 SENDER

The SENDER is a remotely controlled unit containing several signal sources and line terminations, and switching for exchange connection, line looping and line isolation. The warble tone frequency is adjustable so that two or three senders may be distinguishable when used simultaneously on pairs in the same cable.

Signal sources :

- 40kHz sine wave
- 100kHz sine wave
- 300kHz sine wave
- 820Hz sine wave
- 3kHz sine wave
- ~2kHz warble tone

Terminations :

- Open (isolated)
- Loop (short circuit)
- 120 Ω
- 600 Ω
- TN12 complex

3.2 RECEIVER

The RECEIVER contains remote control signalling, several line terminations and several measurement instruments.

To conserve battery energy, the unit automatically switches off after a period of inactivity.

Terminations :

- 120 Ω
- 600 Ω
- TN12 complex

Measuring Instruments :

- DC Voltmeter
- 40kHz, 100kHz, 300kHz, 820Hz and 3kHz Narrowband Voltmeters
- Ohmmeter and Insulation Resistance Meter
- Noise Meter
- Longitudinal Conversion Loss Meter.

3.3 PROBE

The PROBE is a non-contact detector for identification of the pair. If the SENDER is set to Warble Mode and connected to a pair, that pair may be positively identified at the remote end, using the PROBE.

4 OPERATING MODES

The TX120A has 13 operating modes, all selectable by pressing a single button on the RECEIVER.

After connection to the line, the RECEIVER can make a total of 16 different measurements without further connection or disconnection.

In all modes other than Exchange Connect, the exchange side of the Pair Under Test (PUT) is “busied” to incoming calls by a 990Ω resistor placed across the exchange line.

4.1 EXCHANGE CONNECT

This is the power-on mode of the SENDER and is also selectable from the RECEIVER. The PUT is connected through to the Exchange. The RECEIVER measures the DC Line Voltage A leg - B leg. Following this, external instruments may be connected to the PUT via the terminals at the top of the RECEIVER.

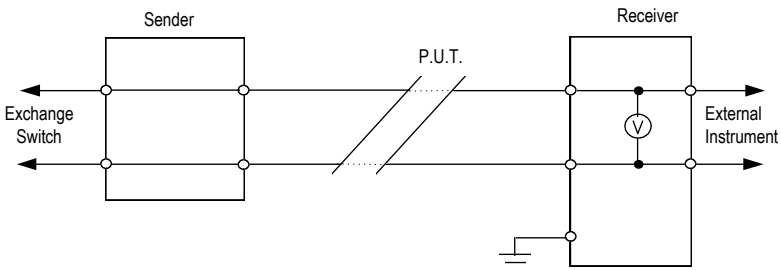

4.2 PAIR IDENTIFICATION

This mode is selectable from the SENDER and from the RECEIVER. A distinctive warble tone is connected to the PUT and can be detected at the remote end using the PROBE.

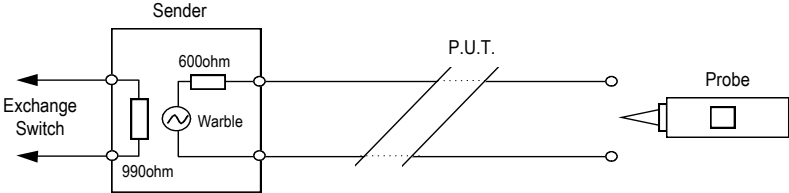

4.3 820Hz INSERTION LOSS

An 820Hz, -10dBm, sinusoidal signal is connected to the PUT at the SENDER. The RECEIVER measures the received level and calculates the Insertion Loss. Either 600Ω or TN12 complex termination may be selected.

Note : The TN12 termination consists of a 220Ω resistor in series with a parallel combination of an 820Ω resistor and a 120nF capacitor.

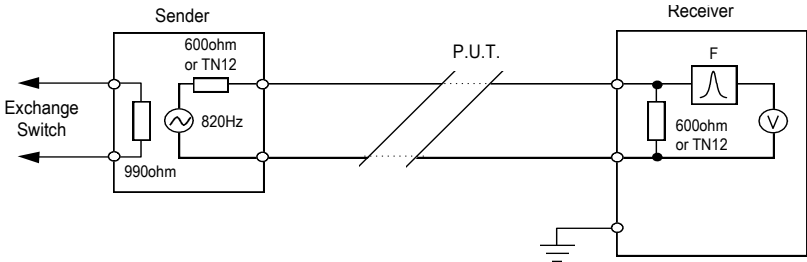

4.4 3kHz INSERTION LOSS

A 3kHz, -10dBm, sinusoidal signal is connected to the PUT at the SENDER. The RECEIVER measures the received level and calculates the Insertion Loss. Either 600Ω or TN12 complex termination may be selected.

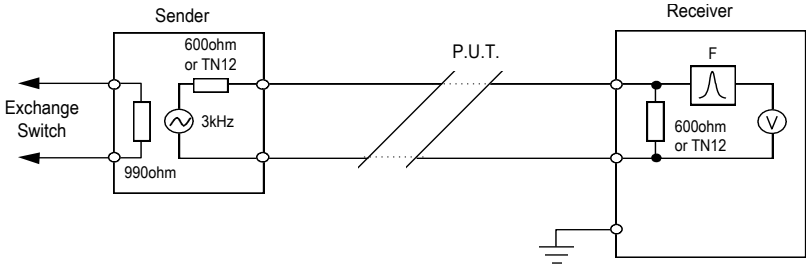

4.5 HIGH FREQUENCY INSERTION LOSS

A 40kHz, 100kHz or 300kHz, 0dBm, sinusoidal signal is connected to the PUT at the SENDER. The RECEIVER measures the received level and calculates the Insertion Loss.

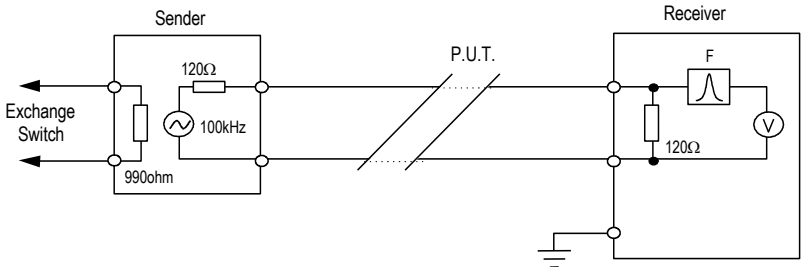

4.6 NOISE

The PUT is terminated in 600Ω at the SENDER and at the RECEIVER, and a 3kHz Flat noise measurement is made using a quasi-peak detector.

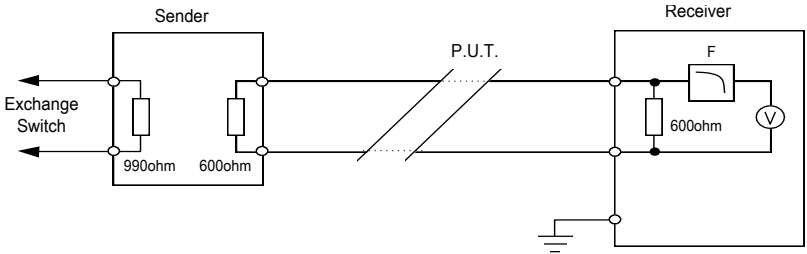

4.7 LINE BALANCE (LONGITUDINAL CONVERSION LOSS - LCL)

The PUT is isolated at the SENDER, and the RECEIVER measures the LCL of the two wires to ground. LCL better than 57dB indicates a well balanced line, less than 51dB , an unbalanced line, and 52dB to 56dB , a reasonably balanced line.

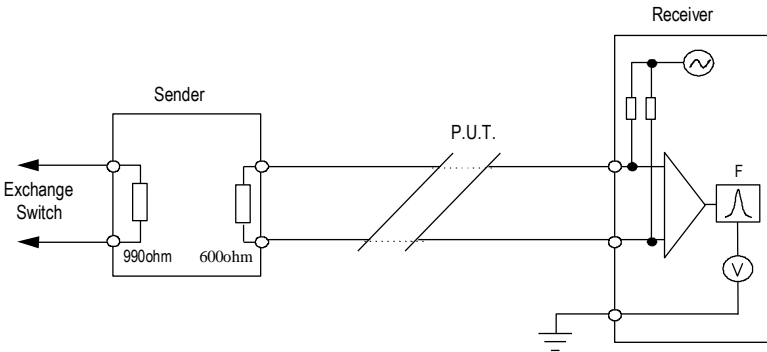

4.8 LINE LOOP / LOOP RESISTANCE

The PUT is looped (short circuited) at the SENDER. The RECEIVER measures the Loop Resistance. Following this, external instruments may be connected to the PUT via the terminals at the top of the RECEIVER.

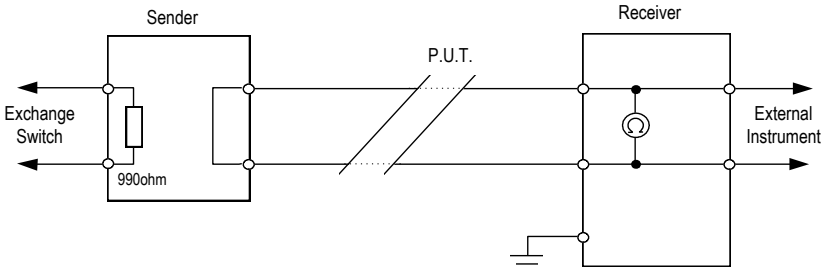

4.9 OPEN

The PUT is opened (isolated) from the exchange and all SENDER circuitry. The RECEIVER measures, in turn, the three DC Voltages A leg - B leg, A leg - Ground, and B leg - Ground. Following this, external instruments may be connected to the PUT via the terminals at the top of the RECEIVER.

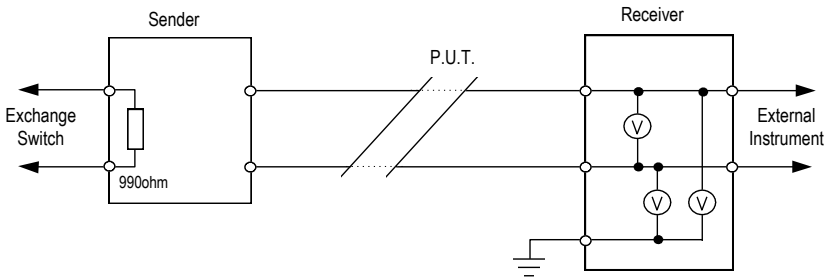

4.10 INSULATION RESISTANCE

The RECEIVER measures three Insulation Resistances, A leg - B leg, A leg - Ground, and B leg - Ground, using a 500V DC source. Each test is continued for 20 seconds in order to allow time for weak insulation to fail.

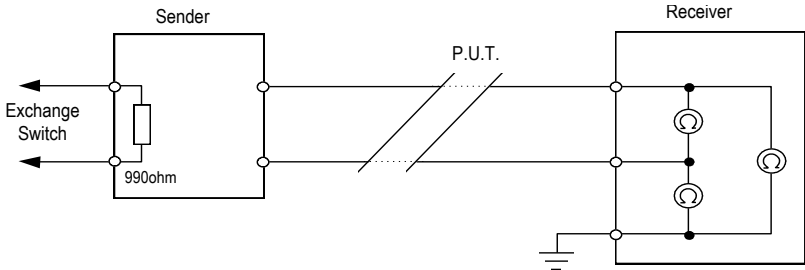

4.11 CALIBRATION CHECK

This test uses the RECEIVER to check the SENDER 820Hz, 3kHz, 40kHz, 100kHz and 300kHz sources and the loop resistance. For the test, the SENDER and RECEIVER are connected to each other using their Alligator Clip Test Leads.

5 USING THE SENDER

5.1 SENDER FEATURES

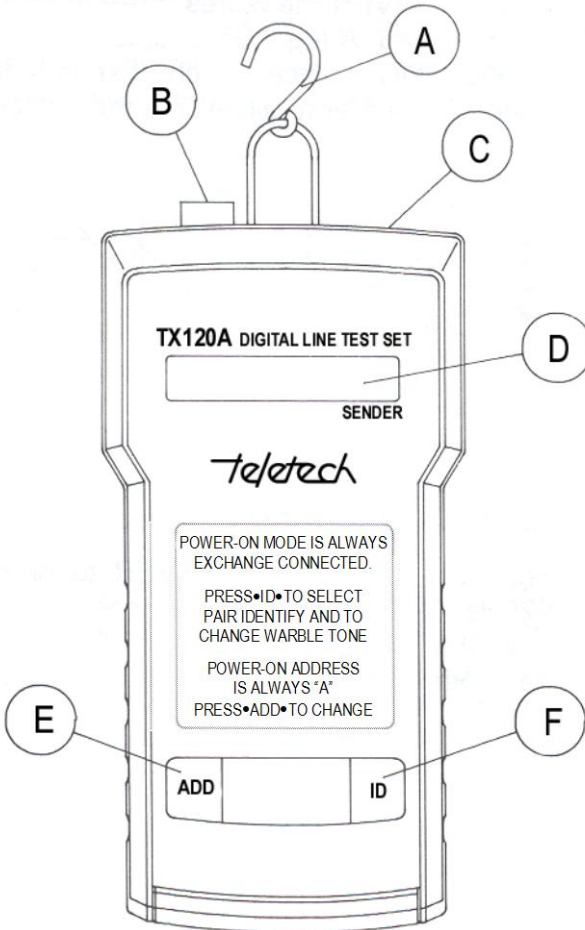

- A. Hook for suspending the SENDER.
- B. Socket for test lead with black plug.
- C. Socket for power lead.
- D. LCD display.
- E. <ADD> button for setting the address.
- F. <ID> button for selection of the Pair Identify mode and setting the pair identification warble tone rate.

5.2 POWER ON

The SENDER is switched on by inserting the test lead, and remains on while the test lead is inserted. Note however, that, to conserve battery energy, the display switches off, five seconds after a message.

When the SENDER is first switched on, the battery is tested and the estimated life remaining (in hours of continuous use) is briefly displayed.

WARNING : Leaving the test lead plugged in when not in use, will reduce battery life by up to 70%! Remember too, that, although the display is off, the power is still on, whenever the test lead is inserted.

5.3 TEST LEADS

The standard one metre test lead has two red and two blue leads with alligator clips. Remove the jumpers between exchange side and customer side. Connect the red leads to the exchange side and the blue leads to the customer side. Connections are not polarity conscious.

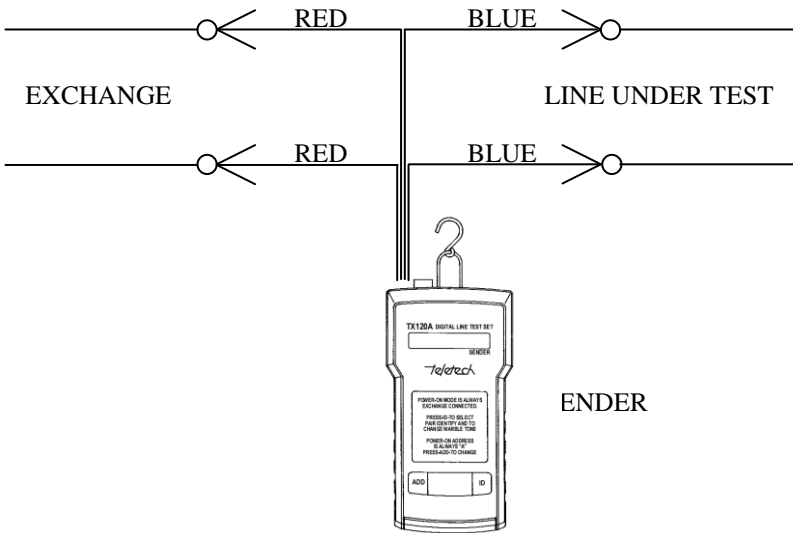

Several other test lead options are available and are listed in Section 11. Except in the case of the alligator clip lead, the connections to the pair under test are made by inserting a polarised isolating plug into a connector block.

5.4 POWER LEAD

When operating inside an exchange, the SENDER may be powered from the exchange battery using the optional power lead listed in Section 11.

5.5 BATTERY TEST

Every ten minutes, the SENDER checks its own battery and, if it is found to be flat, puts a loop on the line. This loop is detected, remotely, by the RECEIVER, which displays a warning that the SENDER battery is flat.

5.6 SELECTING THE OPERATING MODE

When the SENDER is powered ON (by inserting the test lead), it will be in the EXCHANGE CONNECT mode (see Section 4.1). The PUT is connected through to the exchange switch. The display briefly indicates the mode.

By pressing the <ID> button, the mode may be changed to PAIR IDENTIFY, in which the distinctive warble tone is connected to the PUT (see Section 4.2). Again, the display briefly indicates the mode. Further presses of the <ID> button, while the display is on, will sequentially select High, Medium and Low warble rates with the rate shown briefly on the LCD display.

If a return to the EXCHANGE CONNECT mode is required, this can only be achieved by removing and re-inserting the test lead.

All other SENDER modes are selected by control signals sent from the RECEIVER.

The mode displays that will be seen briefly, at the appropriate times are as follows.

EXCHANGE
CONNECTED

PAIR IDENTIFY

820 Hz LOSS
600 Ω

820 Hz LOSS
TN12

LINE ISOLATED

40 kHz LOSS

100 kHz LOSS

300 kHz LOSS

3 kHz LOSS
600 Ω

3 kHz LOSS
TN12

600 Ω TERMINATION

LINE LOOPED

5.7 DISPLAY

In order to save battery energy, the display is on for only five seconds following a power-on, a switch press, or reception of a control signal from the RECEIVER.

5.7.1 BATTERY STATUS INDICATION

When the SENDER is switched on by inserting the test lead, the following message is displayed briefly.

C H E C K I N G S E N D E R B A T T E R Y
--

If the battery is too flat for the SENDER to perform to specification, the following message is displayed and the unit will not operate until the battery is replaced.

R E P L A C E S E N D E R B A T T E R Y
--

If the battery is OK, the approximate number of hours of battery life remaining, will be displayed. This is a guide only (but a good one) as battery consumption is affected by operating mode and temperature.

S E N D E R B A T T E R Y 2 3 H R S R E M A I N
--

5.7.2 WARBLE RATE INDICATION

Press the <ID> button and the display briefly shows the warble rate (LOW, MEDIUM, or HIGH) which is currently selected. To change the rate, while the rate is still displayed, press the <ID> button repeatedly until the desired rate is displayed.

WARBLE RATE
MEDIUM

5.7.3 ADDRESS INDICATION

Press the **<ADD>** button and the display briefly shows the address to which the SENDER is currently set (A, B or C). To change the address, while the address is still displayed, press the **<ADD>** button repeatedly until the desired address is displayed.

ADDRESS
C

6 USING THE RECEIVER

6.1 RECEIVER FEATURES

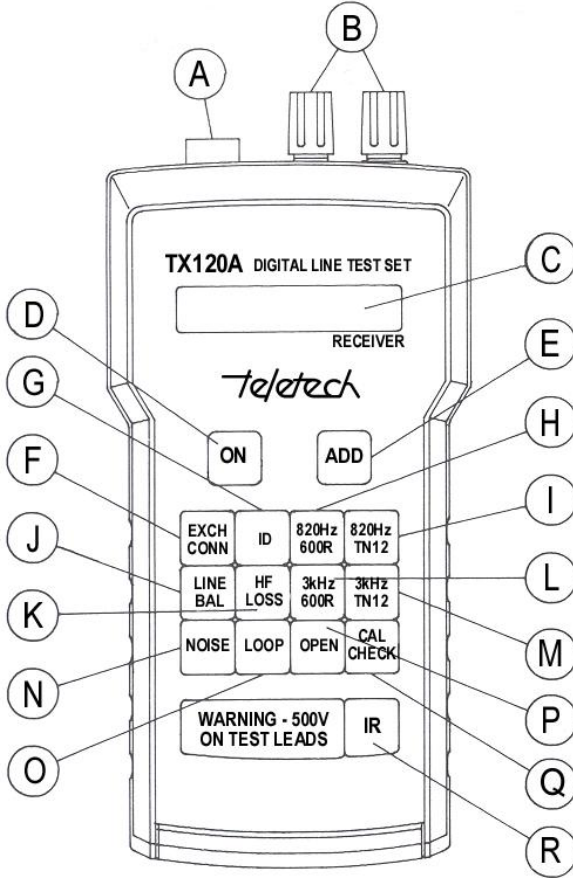

- A. Socket for test lead with grey plug.
- B. Terminals for access to Pair Under Test in Exchange Connect, Open and Loop modes.
- C. LCD display.
- D. **<ON>** button for switching power on (only active when test lead is plugged in).
- E. **<ADD>** button for setting the address.
- F. **<EXCH CONN>** button for selection of Exchange Connect mode and DC line voltage test.
- G. **<ID>** button for selection of Pair Identify mode.
- H. **<820Hz 600R>** button for selection of the 820Hz Insertion Loss test with 600 Ω termination.
- I. **<820Hz TN12>** button for selection of the 820Hz Insertion Loss test with TN12 complex termination.
- J. **<LINE BAL>** button for selection of the Line Balance test.
- K. **<HF Loss>** button for selection of the 40kHz, 100kHz and 300kHz Insertion Loss test with 120 Ω complex termination.
- L. **<3kHz 600R>** button for selection of the 3kHz Insertion Loss test with 600 Ω termination.
- M. **<3kHz TN12>** button for selection of the 3kHz Insertion Loss test with TN12 termination.
- N. **<NOISE>** button for selection of the 3kHz flat Noise test with continuous and peak capture displays.
- O. **<LOOP>** button for selection of Loop mode and the Loop Resistance test.
- P. **<OPEN>** button for selection of Open mode and DC foreign battery voltage test.
- Q. **<CAL CHECK>** button for selection of the back-to-back SENDER / RECEIVER calibration check.
- R. **<IR>** button for selection of the 500V Insulation Resistance test.

6.2 POWER ON

6.2.1 RECEIVER BATTERY CHECK

The RECEIVER is switched on by inserting the test lead and pressing the <ON> button. The unit will not switch on with the test lead removed. It may not be necessary to press the <ON> button.

The following message is displayed briefly.

```
CHECKING  
RECEIVER BATTERY
```

If the battery is too flat for the RECEIVER to perform to specification, the following message is displayed and the unit will not operate until the battery is replaced.

```
REPLACE  
RECEIVER BATTERY
```

If the battery is OK, the following message is displayed, showing the hours of battery life remaining.

```
RECEIVER BATTERY  
37 HRS REMAIN
```

6.2.2 SENDER BATTERY CHECK

When the SENDER battery is too flat to ensure operation to specification, it puts a loop on the line. Whenever the RECEIVER powers up, it checks the loop resistance to determine the status of the SENDER battery.

If a loop is found on the line, the following message is displayed and the SENDER may not respond to the RECEIVER commands.

```
SENDER BATTERY  
MAY BE FLAT
```

Certain fault conditions on the line may also cause an apparent loop, or prevent a loop measurement from being made. In this case, the same message will be displayed.

6.3 POWER OFF

To conserve battery energy, the RECEIVER switches off, automatically, two minutes after the last button is pressed. All existing line conditions are retained when this happens. To re-power the unit, press the **<ON>** button again. Whenever the RECEIVER is re-powered, the RECEIVER and SENDER batteries are checked.

6.4 ADDRESS

The RECEIVER address must be the same as that of the SENDER it is working with (A, B or C). The power-on default address is the address which was in operation when the RECEIVER last powered off. To display the current address, press the <ADD> button. To change the address, press the <ADD> button repeatedly until the required address is displayed.

A D D R E S S C

6.5 TEST LEADS

The standard one metre test lead has two blue leads and one white lead with alligator clips. Isolate the pair under test (PUT) from any line or equipment on the customer side and connect the blue leads to the PUT and the white lead to ground. Blue lead connections are not polarity conscious.

Another test lead option is available as listed in Section 11. In the case of the Krone lead, the connections to the PUT are made by inserting a polarised isolating plug into a connector block. The white lead with the alligator clip must be connected to ground.

WARNING : The white lead must be connected to a good earth if the instrument is to return meaningful results for the LINE BALANCE, OPEN and IR tests.

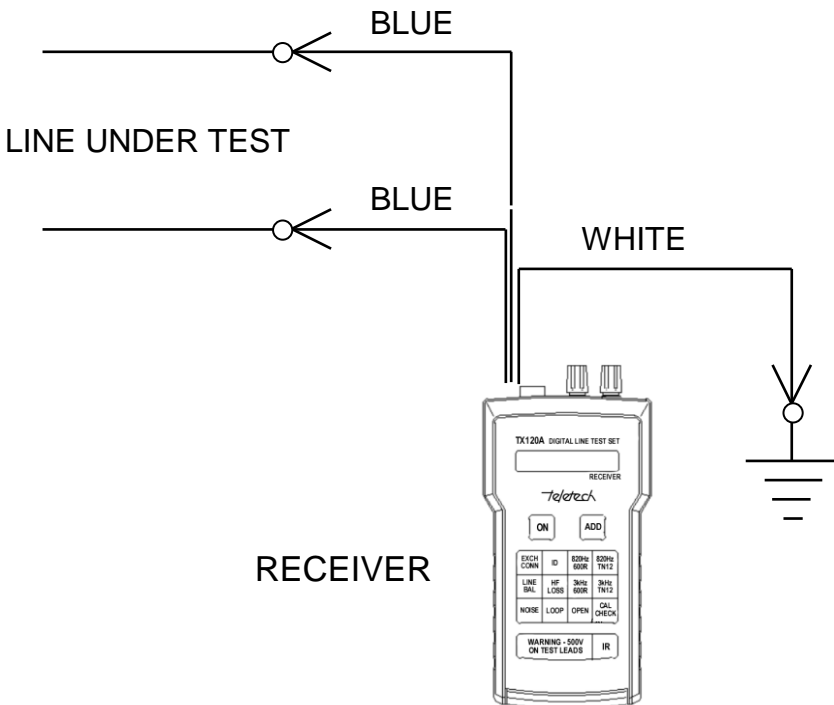

6.6 OPERATING MODE

There are 13 buttons for the selection of the operating mode. The operating modes are explained in Section 4. In all cases except Insulation Resistance, the mode is selected with a single button press. For safety reasons, the 500V IR test requires two sequential presses.

When a mode button is pressed, a coded signal is transmitted to the SENDER to set up the appropriate termination and/or signal source. Allow at least seven seconds for the SENDER to respond.

All tests may be cancelled by pressing any button, except **<ON>**.

6.6.1 EXCHANGE CONNECT MODE

Press the **<EXCH CONN>** button. The processing message is displayed while the SENDER is set up for the test.

```
EXCHANGE CONNECT  
PROCESSING
```

The DC Line Voltage between A-leg and B-leg is then measured once and displayed. The PUT is now available for the connection of external instruments via the two terminals at the top of the RECEIVER.

```
LINE VOLTS = 48  
USE EXT. INSTR.
```

Note that voltage polarity is not displayed. Voltages greater than 400V are displayed as >400.

This display will remain until the RECEIVER powers off automatically, or another mode is selected.

6.6.2 PAIR IDENTIFY MODE

Press the **<ID>** button. The processing message is displayed while the SENDER is set up for the test.

```
PAIR IDENTIFY  
PROCESSING
```

The following message is then displayed.

```
PAIR IDENTIFY  
USE PROBE
```

The SENDER has now connected the warble tone to the PUT and this can be detected using the PROBE.

This display will remain until the RECEIVER automatically powers off or until another mode is selected.

6.6.3 820Hz (600Ω) INSERTION LOSS MODE

Press the **<820Hz 600R>** button. The processing message is displayed while the SENDER is set up for the test.

```
8 2 0 H z ( 6 0 0 R )   L O S S  
P R O C E S S I N G
```

The Insertion Loss is then measured once and displayed until the RECEIVER powers off automatically or another mode is selected. A loss greater than 20dB is displayed as >20dB.

```
8 2 0 H z ( 6 0 0 R )   L O S S  
7 . 8 d B
```

6.6.4 820Hz (TN12) INSERTION LOSS MODE

Press the **<820Hz TN12>** button. The processing message is displayed while the SENDER is set up for the test.

```
8 2 0 H z ( T N 1 2 )   L O S S  
P R O C E S S I N G
```

The Insertion Loss is then measured once and displayed until the RECEIVER powers off automatically or another mode is selected. A loss greater than 20dB is displayed as >20dB.

```
8 2 0 H z ( T N 1 2 )   L O S S  
7 . 4 d B
```

6.6.5 3kHz (600Ω) INSERTION LOSS MODE

Press the **<3kHz 600R>** button. The processing message is displayed while the SENDER is set up for the test.

```
3 k H z ( 6 0 0 R )   L O S S  
P R O C E S S I N G
```

The Insertion Loss is then measured once and displayed until the RECEIVER powers off automatically or another mode is selected. A loss greater than 20dB is displayed as >20dB.

```
3 k H z ( 6 0 0 R )   L O S S  
1 0 . 5 d B
```

6.6.6 3kHz (TN12) INSERTION LOSS MODE

Press the **<3kHz TN12>** button. The processing message is displayed while the SENDER is set up for the test.

```
3 k H z ( 6 0 0 R )   L O S S  
P R O C E S S I N G
```

The Insertion Loss is then measured once and displayed until the RECEIVER powers off automatically or another mode is selected. A loss greater than 20dB is displayed as >20dB.

```
3 k H z ( T N 1 2 )   L O S S  
9 . 9 d B
```

6.6.7 HIGH FREQUENCY INSERTION LOSS MODE

Press the **<HF Loss>** button. Continue pressing the **<HF Loss>** button until correct frequency is displayed. After 5 seconds, the processing message is displayed while the SENDER is set up for the test.

```
1 0 0 k H z   L O S S  
P R O C E S S I N G
```

The Insertion Loss is then measured once and displayed until the RECEIVER powers off automatically or another mode is selected. A loss greater than 60dB is displayed as >60dB.

```
1 0 0 k H z   L O S S  
4 2 . 3 d B
```

6.6.8 NOISE MODE

Press the **<NOISE>** button. The processing message is displayed while the SENDER is set up for the test.

```
N O I S E ( d B m )  
P R O C E S S I N G
```

The Noise level on the PUT is then continuously measured and displayed, together with the highest reading observed (peak hold), until the RECEIVER powers off automatically or another mode is selected.

```
N O I S E ( d B m )  
- 6 9           M A X = - 2 8
```

Note that the larger the number, the lower the noise level. That is, -35dBm is greater than -42dBm.

Noise greater than -20dBm is displayed as >-20 and noise less than -70dBm is displayed as <-70.

6.6.9 LINE BALANCE MODE

Press the **<LINE BAL>** button. The processing message is displayed while the SENDER is set up for the test.

```
LINE BALANCE  
PROCESSING
```

The Longitudinal Conversion Loss (a measure of line balance) will then be measured once and displayed until the RECEIVER powers off automatically or another mode is selected. Also displayed, is a three level assessment of the state of balance of the line :

```
GOOD      >57dB  
FAIR      51 - 57dB  
BAD       <51dB
```

```
LINE BALANCE  
FAIR      LCL = 56 dB
```

The higher the LCL figure, the better the line balance. LCL greater than 75dB is displayed as >75 and LCL less than 45dB is displayed as <45.

6.6.10 LINE LOOP MODE

Press the <LOOP> button. The processing message is displayed while the test is set up. During this time, the PUT is checked for the presence of foreign battery.

```
LINE LOOPING  
PROCESSING
```

The PUT is now looped at the SENDER and the Loop Resistance is measured once and displayed until the RECEIVER powers off automatically or another mode is selected.

Access to the PUT is now available via the External Instrument terminals at the top of the RECEIVER.

Loop Resistance greater than 3000Ω is displayed as $>3000\Omega$.

```
LOOP RES . 1230Ω
```

```
USE EXT. INSTR.
```

If the RECEIVER detects foreign battery on the line, it will not measure the Loop Resistance but will display the following message.

```
FOREIGN BATTERY  
LOOP NOT DONE
```

6.6.11 OPEN MODE

Press the <OPEN> button. The processing message is displayed while the SENDER is set up for the test.

```
LINE ISOLATION  
PROCESSING
```

The DC Voltage between A-leg and B-leg is then measured once and displayed.

```
DC VOLTS AB = 43
```

The DC Voltage between A-leg and Ground is then measured once and displayed, together with the A-leg to B-leg voltage.

```
DC VOLTS AB = 43  
AG = 11
```

The DC Voltage between B-leg and Ground is then measured once and displayed, together with the A-leg to B-leg and A-leg to Ground voltages.

```
DC VOLTS AB = 43  
AG = 11 BG = 13
```

This display is held for two seconds before changing to the following message.

```
LINE ISOLATED  
USE EXT. INSTR.
```

The two displays then alternate at two second intervals.

Access to the PUT is now available via the External Instrument terminals at the top of the RECEIVER.

Note that voltage polarity is not displayed. Voltages greater than 400V are displayed as >400.

6.6.12 500V INSULATION RESISTANCE MODE

Press the <IR> button. The processing message is displayed while the test is set up. During this time, the PUT is checked for the presence of foreign battery.

```
500V IR  
PROCESSING
```

If there is no foreign battery, the following three messages are displayed sequentially, changing at two second intervals, continuously, until a button is pressed.

```
PRESS <IR>  
TO START
```

```
*WARNING* 500V  
ON TEST LEADS
```

```
PRESS ANY GREY  
BUTTON TO STOP
```

At any time, either prior to starting the test, or during the test, if any button other than <ON> is pressed (including the <IR> button), a new test will be initiated. If the test is running at the time, the 500V will be switched off and the line immediately discharged.

Once the test is started, the following message is displayed with the number of seconds remaining before the IR(A-B) is measured.

5 0 0 V	IR (A - B)
2 0	SEC REMAINING

At 0 seconds, the Insulation Resistance between A-leg and B-leg is measured once and displayed for five seconds.

IR (M Ω)	AB = > 2 0 0
-------------------	--------------

The following message is then displayed with the number of seconds remaining before the IR(A-G) is measured.

5 0 0 V	IR (A - G)
1 5	SEC REMAINING

At 0 seconds, the Insulation Resistance between A-leg and Ground is measured once and displayed for five seconds, together with the Insulation Resistance A-leg to B-leg.

IR (M Ω)	AB = > 2 0 0
AG =	1 7 0

The following message is then displayed with the number of seconds remaining before the IR(B-G) is measured.

5 0 0 V	IR (B - G)
1 5	SEC REMAINING

At 0 seconds, the Insulation Resistance between B-leg and Ground is measured once and displayed, together with the Insulation Resistances A-leg to B-leg, and A-leg

to Ground, until the RECEIVER powers off automatically or, another mode is selected.

IR (M Ω)	AB = > 2 0 0
AG =	1 7 0
BG =	1 8 0

Note that resistances greater than 200MΩ are displayed as >200, and resistances less than 1MΩ are displayed as 1MΩ.

If the RECEIVER detects foreign battery on the line, it will not measure the Insulation Resistance but will display the following message.

```
FOREIGN BATTERY  
IR TEST NOT DONE
```

WARNING : For 60 seconds during this test, there is 500VDC present on the test leads and on the line under test. It can be removed, at any time, by pressing any button other than **<ON>**. While this voltage is not lethal (because it is current limited to 2mA), it will give an electric shock.

WARNING : Do not disconnect the test leads from the line during a test as this will leave the line in a charged state capable of causing an unpleasant electric shock. The TX120A discharges the line at the completion of the test.

6.6.13 CALIBRATION CHECK MODE

Press the **<CAL CHECK>** button. The following instruction message is displayed.

```
SENDER - REC ( BLUE )  
PRESS CAL CHECK
```

Plug the alligator clip test leads into SENDER and RECEIVER and press the RECEIVER **<ON>** switch if necessary. Clip the blue SENDER wires to the blue RECEIVER wires and press the **<CAL CHECK>** button again to start the test. The following tests will be done, in sequence, with PASSED or FAILED displayed after each.

- 820Hz CHECK
- 3kHz CHECK
- LOOP CHECK
- 40kHz CHECK
- 100kHz CHECK
- 300kHz CHECK

A "pass" display sequence will be as follows.

8 2 0 H z C H E C K

8 2 0 H z C H E C K
P A S S E D

3 k H z C H E C K

3 k H z C H E C K
P A S S E D

L O O P C H E C K

L O O P C H E C K
P A S S E D

4 0 k H z C H E C K

4 0 k H z C H E C K
P A S S E D

1 0 0 k H z C H E C K

1 0 0 k H z C H E C K
P A S S E D

3 0 0 k H z C H E C K

3 0 0 k H z C H E C K
P A S S E D

C A L C H E C K
P A S S E D

If any test fails, the CAL CHECK will be reported as having failed.

CAL CHECK FAILED

7 USING THE PROBE

7.1 PROBE FEATURES

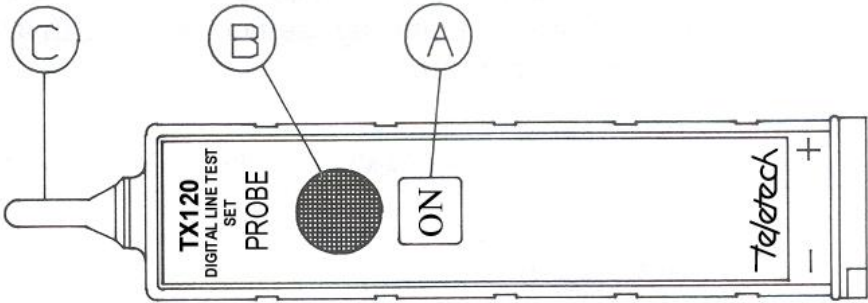

- A. ON switch to turn the Probe on.
- B. Speaker grill.
- C. Probe tip.

7.2 OPERATION

Hold the PROBE in your hand, press the **<ON>** button and hold the tip in the vicinity of the pair to be identified.

The distinctive warble tone will be at a maximum level when the PROBE is close to the correct pair.

Due to capacitive coupling, the warble tone may be detected on pairs other than the correct one. The correct pair will have a null (minimum signal level) between the two wires. There will be no null between wires of other pairs.

The PROBE is only switched on and operating when the button is held down.

An optional earphone (see Section 11) may also be used with the PROBE to effectively increase sensitivity, particularly in areas with high background noise levels.

8 APPLICATIONS

8.1 USING DIFFERENT WARBLE RATES

Up to three SENDERS may be used concurrently on three different pairs by setting each SENDER to a different warble rate.

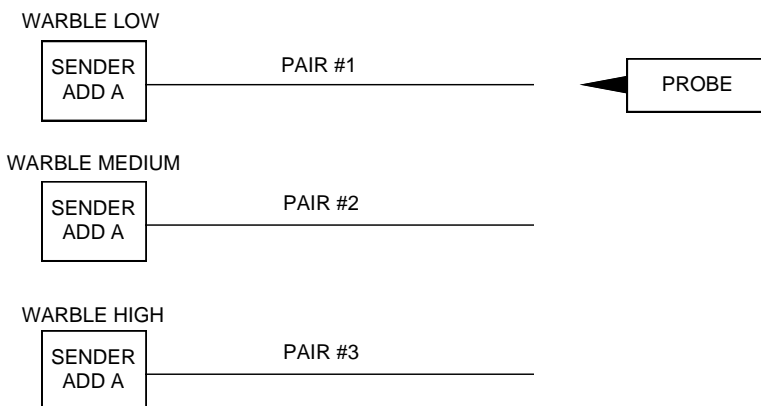

8.2 USING DIFFERENT ADDRESSES

Up to three SENDERS may be used on a single pair to save time and travelling when testing a long line.

Say a pair gain system is to be installed on a long line and two repeaters are to be used. The section of line from the exchange to the first repeater site is tested with SENDER and RECEIVER set to Address A.

The SENDER at the exchange is then set to EXCH CONN mode and a second SENDER, set to Address B, is positioned at the first repeater site. The section of line from here to the second repeater site is then tested with the RECEIVER set to Address B.

This process can then be repeated one more time using Address C.

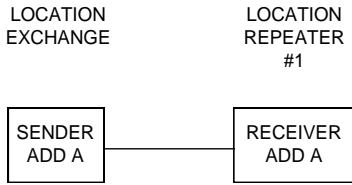

a) Testing the first section of a long line

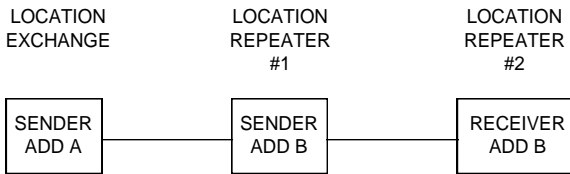

MODE EXCH CONN

b) Testing the second section of a long line

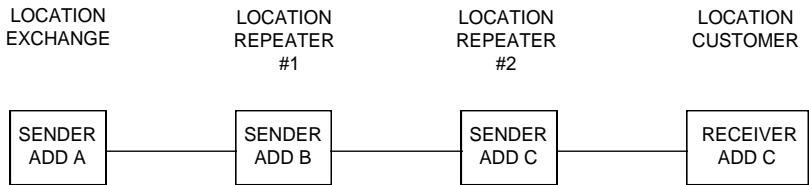

MODE EXCH CONN

MODE EXCH CONN

c) Testing the third section of a long line

9 TROUBLESHOOTING

FAULT	ACTION
SENDER	
No display	<ul style="list-style-type: none"> • Check that a correct test lead (black plug) is plugged in. • Replace battery.
Does not respond to press of ADD button.	<ul style="list-style-type: none"> • Return to supplier for repair.
Does not respond to press of ID button.	<ul style="list-style-type: none"> • Return to supplier for repair.
Does not reset to EXCH CONN mode when test lead is removed and re-inserted.	<ul style="list-style-type: none"> • Return to supplier for repair.
RECEIVER	
No display.	<ul style="list-style-type: none"> • Check that a correct test lead (grey plug) is plugged in. • Press <ON> button. • Replace battery.
Does not respond to button presses.	<ul style="list-style-type: none"> • Return to supplier for repair.
SENDER does not respond but line is known to be good.	<ul style="list-style-type: none"> • Check that RECEIVER address is set to same as SENDER address. • Check that the SENDER is connected correctly - red leads to exchange, blue leads to Pair Under Test. • Check that jumpers between exchange and customer are removed.

FAULT	ACTION
-------	--------

RECEIVER	
CAL CHECK fails.	<ul style="list-style-type: none"> • Check that the SENDER blue test leads are clipped to the RECEIVER blue test leads. • Try SENDER with a different RECEIVER and RECEIVER with a different SENDER to determine which unit is faulty. • Return faulty unit to supplier for repair.
PROBE	
No warble tone heard.	<ul style="list-style-type: none"> • Check that SENDER display shows a warble rate and try the Probe with no line connected to SENDER. • Replace battery.

10 TECHNICAL SPECIFICATIONS

DC VOLTAGE

Tests (OPEN mode)	A-B, A-GND, B-GND
Tests (EXCH CONN mode)A-B	
Range / Resolution	-400V to +400V / 1V
Input Impedance	200k Ω

820Hz INSERTION LOSS

Range / Resolution	0 to 20dB / 0.1dB
Send Level	-10dBm
Impedance	600 Ω , TN12 complex

3kHz INSERTION LOSS

Range / Resolution	0 to 20dB / 0.1dB
Send Level	-10dBm
Impedance	600 Ω , TN12 complex

40kHz,100kHz, 300kHz INSERTION LOSS

Range / Resolution	0 to 60dB / 0.1dB
Send Level	0dBm
Impedance	120 Ω complex

NOISE

Tests	Continuous and peak hold
Range / Resolution	-70dBm to -20dBm / 1dB
Weighting	3kHz flat
Detection	Quasi-peak

LINE BALANCE

(LONGITUDINAL CONVERSION LOSS)

Range / Resolution	45dB to 75dB / 1dB
Source	1Vrms, 3kHz, sinusoidal

LOOP RESISTANCE

Range / Resolution	0 to 3,000 Ω / 1 Ω
Source Voltage	2.5V

INSULATION RESISTANCE

Tests	A-B, A-GND, B-GND
Range / Resolution	0 to 200M Ω / 1M Ω
Source Voltage	500V
Duration	20sec x 3

SENDER PHYSICAL

Dimensions	216 x 100 x 40 mm
Power Supply	-48v exchange battery or internal battery
Internal Battery	9 volt alkaline
Battery Life	Typically 120 hours

RECEIVER PHYSICAL

Dimensions	220 x 100 x 40 mm
Battery	9 volt alkaline
Battery Life	Typically 40 hours

PROBE PHYSICAL

Dimensions	163 x 33 x 23 mm
Battery	9 volt alkaline
Battery Life	Typically 150 hours

ENVIRONMENTAL

Operating Temperature	0 to 50°C
Ingress Protection	IP54

ORDER CODES

Digital Line Test Set to Australian line conditions and comprising -	TX120A
<ul style="list-style-type: none"> • 1 x Sender • 1 x Receiver • 1 x Probe • 1 x 1m Sender Alligator Clip Test Lead • 1 x 1m Receiver Alligator Clip Test Lead • 1 x Soft Carry Case • 1 x Operating Instruction Manual 	
Sender	120ATX
Receiver	120ARX
Probe	120APR
Soft Carry Case	120A/SCC
1m Sender Alligator Clip Test Lead	120A/10GP
1m Sender Siemens Series 71 Test Lead	120A/10S1
1m Sender Siemens Series 2000 Test Lead	120A/10S2
1m Sender Siemens Series 5000 Test Lead	120A/10S3
3m Sender MDF Battery Jack Power Lead	120A/10PL
1m Receiver Alligator Clip Test Lead	120A/12
1m Receiver Krone Test Lead	120A/12K2
Probe Earphone	EPC
Operating Instruction Manual	120A/41

**Teletech Pty Ltd
61 Betula Avenue
Vermont
Victoria 3133
Australia**

(PO Box 85)

**Telephone
Fax
Email
Internet**

**+61 3 9873 2777
+61 3 9873 5902
gen@teletech.com.au
www.teletech.com.au**

TX120A operating instructions ver1.doc